

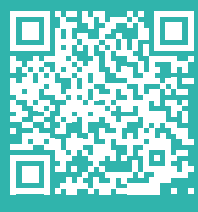

QA-POWER-M | QA-POWER-M-LV



Visit the product page for news, updates and downloads



QA-POWER-M

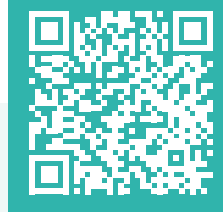

QA-POWER-M-LV

CONTENTS

- Product overview 3
- Inputs 4
- Outputs 4
- Communication interface 4
- Reports and alerts 4
- Data logging 4
- Technical specifications 5
- Electrical characteristics 5
- Available measurements 6
- Communication characteristics 6
- General data 6
- Order codes 7
- Connection and installation 8
- RS485 bus termination 11
- Example of how to use a current transducer 11
- Status LEDs 12
- Data logging – data acquisition 12

- Product features 13
- Modbus 13
- Inputs/output 13
- Analogue output alarm 14
- Digital output alarm – pulse counter 14
- Device configuration 16
- Dip-switch Modbus RTU address and baud rate setting 16
- Functionality configuration 16
- Q-WIZARD 16
- Third-party Modbus Master 17
- Function 03 Hexadecimal (Read Holding Registers) 18
- Function 06 Hexadecimal (Write Single Holding Register) 19
- Function 10 Hexadecimal (Write Multiple Registers) 20
- Firmware update 20
- Register map 21



SAFETY WARNINGS AND CAUTIONS

The following warnings and cautions must be observed to ensure personal safety and prevent damage.



Death or **serious injury** may result from failure to heed this warning.



It is necessary to comply with national regulations when installing and picking materials for power lines.



Material damage or **serious personal injury** may result from failure to heed this warning.



Repairs and modifications must be carried out only by the manufacturer. It is forbidden to open the case and make any changes to the device. Tampering with the device will invalidate the warranty.



The manufacturer **declines all responsibility** for electrical safety in the event of improper use of the equipment.



It is essential to read the entire contents of this manual before carrying out any work.



The product described in this document may only be used for the specified application. The maximum performance data and environmental conditions specified in the product data sheet must be observed. Proper transport and storage, as well as professional assembly, installation, handling and maintenance are required for the correct and safe operation of the device.



Before commissioning, make sure that:

- the maximum values for all connections are not exceeded; refer to the product data sheet;
- the connection cables are not damaged or live during wiring;
- the direction of current flow and phase rotation are correct.

Use under ambient conditions other than those specified, application of signals or voltages other than those specified, may cause significant deviations from the specified measurement tolerances, which may be irreversible.

During installation, ensure that a switch or circuit-breaker is near the product and easily accessible.

The unit must be uninstalled if safe operation can no longer be guaranteed (e.g. visible damage). Disconnect all connections in this case. The unit should be returned to the manufacturer or to an authorised service centre for repair.



Although the contents of this document have been checked for accuracy, it may contain errors or inconsistencies and we cannot guarantee its completeness or accuracy.



This document is subject to periodic revision and updating. QEED reserves the right to make changes to the product and/or its technical documentation at any time in the interests of continuous quality improvement. Always consult the latest version of the documentation available on the website:



WARNING: High-intensity magnetic fields may alter the values measured by the transformer. Avoid installation near: permanent magnets, electromagnets, or iron masses. If irregularities are detected, reposition or move the unit to a more suitable location.

🌐 www.qeed.it

If you find any errors or missing information in this document, please notify us by e-mail to:

✉ technical@qeed.it



Failure to observe the warnings may result in damage to the equipment or failure to operate as intended.



Disposal of waste electrical and electronic equipment (applicable in the European Union and other countries with separate collection). The symbol on the product or its packaging indicates that the product should not be treated as household waste. Instead, it will be handed over to an authorised collection point for the recycling of electrical and electronic waste. Ensuring that the product is disposed of properly will prevent potential negative effects on the environment and human health, which could otherwise be caused by inappropriate waste management of the product. Recycling materials helps to conserve natural resources. For further information, please contact your local authority, waste disposal service or the retailer from whom you purchased the product.



Please note that the information on the nameplate must be observed.





PRODUCT OVERVIEW

The QA-POWER-M is a single phase AC/DC direct insertion power meter that can also be used as a voltage/current isolator. It can be used as a 1000V_{DC} - 600V_{AC} (100V_{DC} - 60V_{AC} for LV version), 10A AC/DC direct insertion or current transformer and variable frequency measurement. Input for voltage transducers up to 70mV only factory adaptable to customer specification. Complete galvanic isolation between power supply, serial and USB interface, inputs and outputs. Power/error/communication/output status LEDs are on the front of the case. Power/error/communication/output status LEDs are on the front of the case.

RS485 serial interface for communication with Modbus RTU protocol, either from the **Q-WIZARD configuration tool (download at link)**, or with third party Modbus masters by acting on register map registers.

Data logger with non-volatile memory for managing the totalisation of input pulses. Allows data to be recorded on a pendrive or PC via USB and downloaded in .csv format, including date and time (RTC - Real Time Clock - built in).

Ready for DIN rail mounting with T-BUS terminal (optional) for fast connection with hot insertion/removal option.

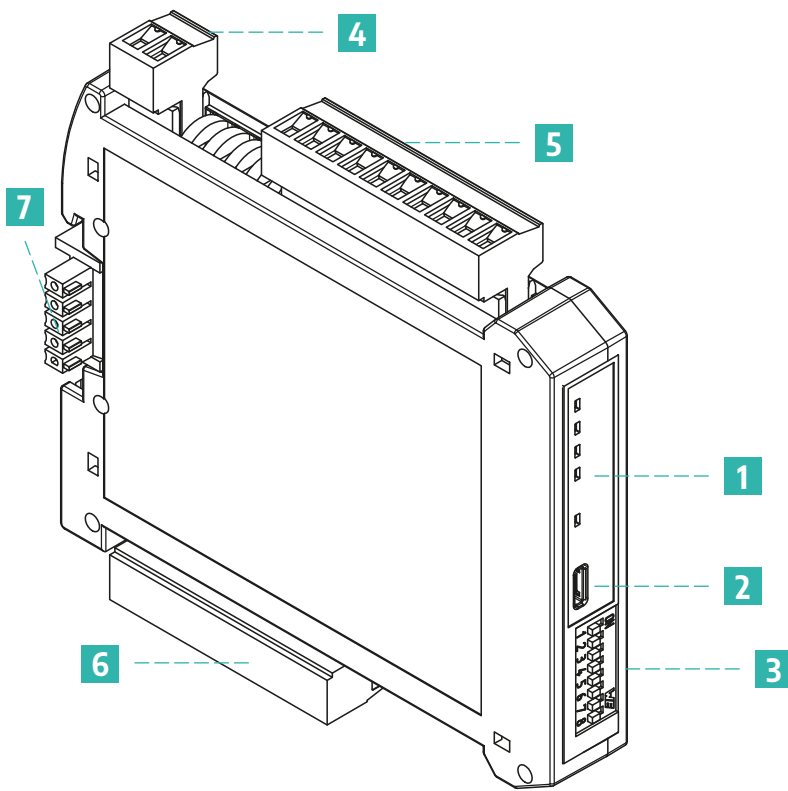

- 1 Status LEDs
- 2 MicroUSB Port
- 3 Settings DIP switch
- 4 Power supply terminals
- 5 Input terminals
- 6 Output terminals
- 7 T-BUS terminal for both power supply and Modbus RTU communication (optional)



Inputs

- **Voltage:** up to 1000V_{DC} / 600V_{AC} (or 100V_{DC} / 60V_{AC} for the -LV version)
 - **Current:** (only one inputs listed below per time can be used)
 - direct insertion up to 10A AC/DC (Transformation ratio = 1)
 - via CT with current output
 - via CT with voltage output up to 100mV_{pk} [$\pm 100\text{mV}_{\text{DC}}$ or 70mV_{AC,RMS}] (or 5V_{pk} [$\pm 5\text{V}_{\text{DC}}$ or 3.5V_{AC,RMS}] depending on the ordered code)
- WARNING: Non-insulated input** from the measured input voltage (input subject to the applied reference potential).
Use a transducer with adequate insulation class (eg. rogowski probe).

Outputs

- **Voltage:** configurable* 0-10V, minimum load resistance 2k Ω
- **Current:** configurable* 0...20mA, maximum load resistance 600 Ω
- **Alarm contact:** Optomos contact, NO on alarm (configurable) or pulse retransmission for totalization, configurable via **Q-WIZARD** software

Communication interface

- **RS485 Modbus RTU:** connection to RS485 serial bus on module base via adapter (T-BUS optional) or terminals. Front dip-switch for manual setting of address and baud rate
- **USB** for configuration

* Using the configuration software, it is possible to scale the inputs and outputs as required, selecting the input measurement interval (**low limit input range** and **high limit input range** parameters in the configuration software) to which the analogue output signal is assigned (**low limit output range** and **high limit output range** parameters in the configuration software).

If manual control via Modbus RTU is selected from the interface, it is possible to manage the module as if it were an AO (Analogue Output) or a DO (Digital Output), thus freeing the analogue and digital output from the selected input. The analogue output is managed via the RS485 Modbus RTU (see register map).

Reports and alerts

The device notifies the user of the following faults via the LED interface:

- Input signal below threshold
- Input signal above threshold
- HW error in the measurement chain
- LOG problem of the real time clock storing the date and time
- RTC problem during data acquisition (no memory on USB stick, USB stick not recognised)
- EEPROM problem on the configuration microprocessor (module out of order, configuration lost)

These anomalies can also be associated with the analogue and/or digital output (even simultaneously) in the form of alarms.

An additional alarm can also be associated with the analogue and/or digital output on the input measurement reported at the output; depending on the configuration software settings, this alarm can be triggered when the measurement is above/below a set threshold or between/beyond 2 set thresholds.

PLEASE NOTE: in the event of an alarm, the output is set to 21mA or 10.5V depending on the analogue output mode setting (current or voltage) selected via the configuration software.

Data logging

It is possible to activate the LOG function for data acquisition on a USB flash drive from the configuration software's dedicated menu.

The extension of the log file can be of the following types: .xls, .xlsx, .csv, .txt, .dat, .log and can be changed by simply changing the extension to the file name in the configuration tool's save box. The default extension is text.

The minimum sampling time is 1 second and the maximum is approximately 18 hours.



TECHNICAL SPECIFICATIONS

Electrical characteristics

	QA-POWER-M	QA-POWER-M-LV
Voltage input	up to 600V _{AC} , 1000V _{DC}	up to 60V _{AC} , 100V _{DC}
Power supply	10 ÷ 40 V _{DC} or 20 ÷ 28 V _{AC} @50/60Hz	
Current consumption	250mA	
Isolation	4kV _{RMS} between power supply and measurement inputs 4kV _{RMS} between RS485 and measurement inputs 1.5kV _{RMS} between power supply and RS485	
Outputs	- Analog: <ul style="list-style-type: none"> Voltage: configurable* 0-10V, minimum load resistance 2kΩ Current: configurable* 0...20mA, maximum load resistance 600Ω - Digital (optoMOS NO, 1-form-A, 30V, <50mA)	
Communication interface	RS485 Modbus RTU microUSB port	
Visual interface	Status LEDs	
Measurement type	TRMS, DC	
Measurement frequency	DC or 40 ÷ 400Hz (measured on voltage channel)	
Sampling frequency	4800 samples/s	
Measurement update	Every 100ms	
CT Current Ratio	Settable via software	
Precision class	0,5% F.S.	
Voltage input		
Input impedance	1MΩ	
Rated capacity (I _n)	600V _{LN_AC} (1000V _{DC})	60V _{AC} (100V _{DC})
Continuous Overload (U _{MAX})	1100V _{LN_DC}	110V _{DC}
Overload for 500 ms	1200V _{LN_DC}	120V _{DC}
Current input		
Direct insertion	up to 10A AC/DC	
Using current output type CT	Rated capacity (I _n)	5A _{AC}
	Crest factor	<3
	Impedance	<0,5Ω
	Continuous overload (I _{MAX})	6A _{AC}
	Overload for 500 ms	40A _{AC}
Using voltage output type CT	Rated capacity 100 mV _{pk} (±100 mV _{DC} or 70 mV _{AC_RMS}) or 5 V _{pk} (±5 V _{DC} or 3.5 V _{AC_RMS}) depending on the ordered code	
Precision (@25°C, 50Hz)		
Voltage (U _n : 230/400 V)	± 0,5% F.S.	
Current (I _n = 5A)	± 0,5% F.S.	
Frequency (40 ÷ 70Hz)	± 0,1Hz	
Power	ACTIVE: ± 0,5 F.S. REACTIVE: ± 0,5 F.S.	
Energy	1% on reading	
Power factor	± (0,001 +1%(1.00-PF))	
Passband (-3dB)	>2kHz	
Temperature coefficient	<200ppm/°C	





Available measurements

I_{rms} - V_{rms}	Frequency
I_{pk} - V_{pk}	$\cos\Phi$
Active power (W), Reactive power (VAR), Apparent power (VA)	THD
Bi-directional energy (kWh), positive and negative	

Communication characteristics

Protocol	Modbus RTU
Baudrate	1200÷115200 bps (default 9600)
Addresses	1÷247 (default 1)
Data format	1 start bit, 8-bit data, NO/ODD/EVEN parity (default NO parity)
Response delay	1÷1000ms
Connection	Via removable terminal, T-BUS or microUSB

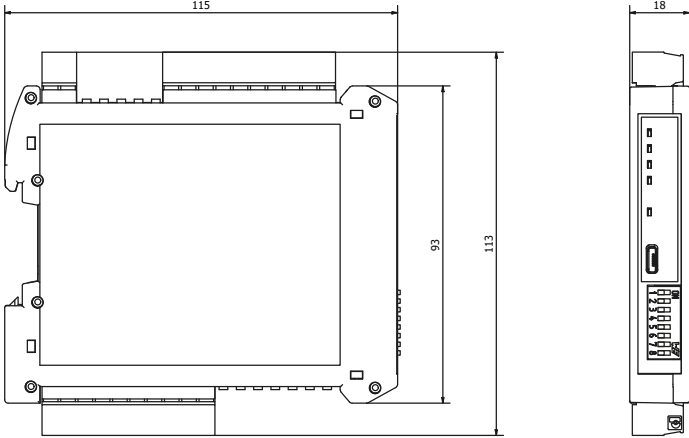
General data

Working temperature	-15÷60° C
Storage temperature	-40÷85° C
Relative humidity	10÷90% not condensing
Elevation	Up to 2000m a.s.l.
Protection degree	IP20
Measurements	115x113x18 mm 
Weight	120 g
Terminal cable cross-section	0.05÷1.5 mm ² (30÷14 AWG)
Energy values storage	Flash, min. 100k writings
Appliance class	Cat. III (IEC 60664, EN60664)
Approvals and certifications	EN 61000-6-3 + A1 2011; EN64000-6-2/2005; EN61010-1/2010 
Installation	Inside electrical panels and mounted on a DIN rail

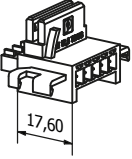
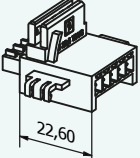

Order codes

Standard version	QA-POWER-M
Low voltage version	QA-POWER-M-LV
Standard version with input for CT with 5V _{pk} output	QA-POWER-M-5V
T-BUS	 QA-TBUS-17,5 width 17,6mm
	 QA-TBUS-22 width 22,6mm



CONNECTION AND INSTALLATION

The instrument is designed to be installed inside electrical panels and mounted on a DIN rail, with or without the aid of the T-BUS connector for interfacing multiple instruments with reduced cabling.

All connection terminals are shown on the pad print on the product and correspond to the figure below:

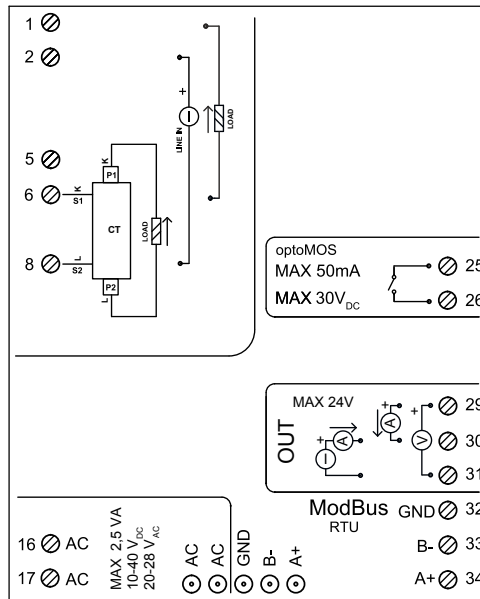

The functionality of the terminals is described below:

<p>16 AC 17 AC</p> <p>MAX 2,5 VA 10-40 V_{ac} 20-28 V_{ac}</p>	<p>Device power supply. Please note: Wiring must be protected against short circuits and/or accidental faults</p>
	<p>Voltage/current input (direct insertion): Input voltage (LINE) must be connected to terminals 2(+) and 8, Load must be connected to terminals 1(+) and 6</p> <p>The measurement range can be set using the configuration software, or via RS485 using Modbus RTU registers</p>

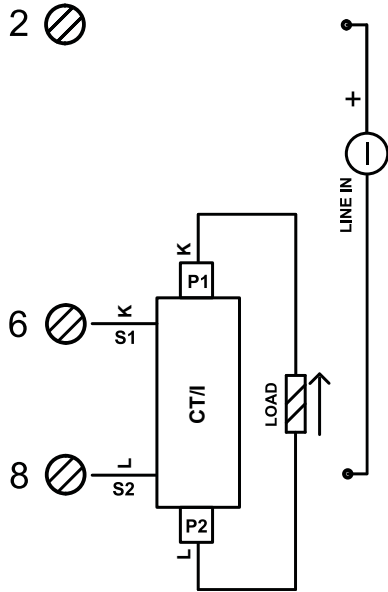

Input with external current transformer (CT) and current output:
Input voltage (LINE) must be connected to terminals 2(+) and 8.
External current transformer connected as described below:

- Terminal S1 of the CT connected to terminal 6
- Terminal S2 of the CT connected to terminal 8
- Connection of the load to the CT, input side P1 and output side P2 (see side diagram on the product box)

With this configuration, the transformation ratio can be set via configuration software or via RS485 using Modbus RTU registers.

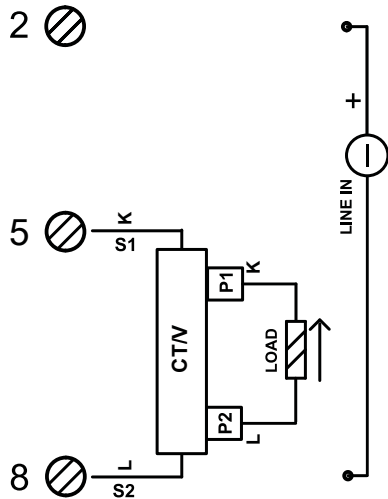

Input with external current transformer (CT) and voltage output (max. 100mV or 5V peak based on the chosen configuration):
The input voltage (LINE) must be connected to terminals 2(+) and 8.

External CT connected as follows

- Terminal S1 of the CT connected to terminal 5
- Terminal S2 of the CT connected to terminal 8
- Load connection to CT, input side P1 and output side P2

WARNING: Non-insulated current input from the measured input voltage (input subject to the applied reference potential). Use a transducer with adequate insulation class (e.g. Rogowski probe).

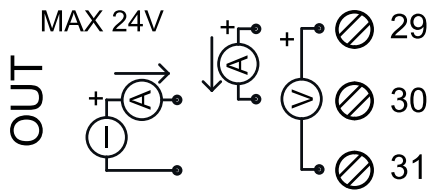

Analogue output:

- For analogue output in voltage, connect terminals 31 and 29 (positive).
- For analogue output in active current, connect terminals 29 (positive) and 30
- For analogue output in passive current, connect terminals 30 (positive) and 31

Sensor power supply from analogue output: 13VDC, 30mA maximum

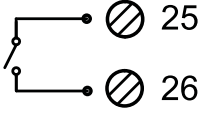
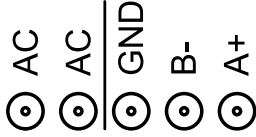

<p>RELAY MAX 50mA MAX 30Vdc</p> 	<p>Digital output: The relay output is an OptoMOS contact. It is connected between terminals 25 and 26. The contact can be used as a pulse output (pulse value configurable via configuration software or via RS485 using Modbus RTU registers) or as an alarm contact (parameter configurable via configuration software or via RS485 using Modbus RTU registers). The digital output is inactive by default</p>
<p>ModBus RTU</p> <p>GND 32</p> <p>B- 33</p> <p>A+ 34</p>	<p>RS485 serial interface: available on terminals 32 (GND), 33 (B-), 34 (A+), or via accessory T-BUS accessory to be placed on the base of the board</p>
	<p>T-BUS connection (requires optional T-BUS accessory): the T-BUS accessory can be fitted to the module base to provide both power supply and serial communication (see figure below). The number of modules supported by the bus depends on the power supply used (please check the power consumption of the modules)</p>

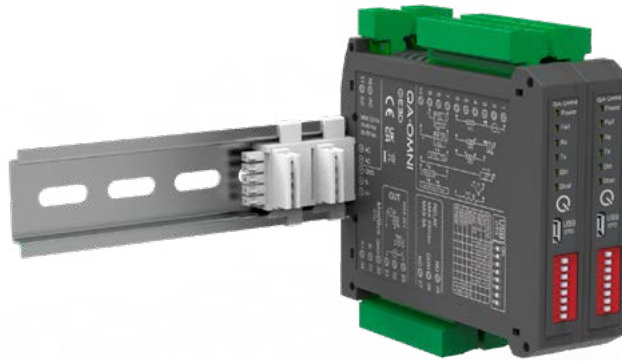

Figure 1: DIN-rail installation with T-BUS

RS485 bus termination

To avoid unbalances on the transmission bus, it is advisable to insert a termination resistor at the beginning of the RS-485 bus (typically on the USB-RS485 adapter) and at the end (typically on the last slave - which can also be activated by dip-switch). It is advisable to use 120Ω resistors with 1% tolerance, which corresponds to the typical impedance of RS485 cables.

The following images are for illustrative purposes only:

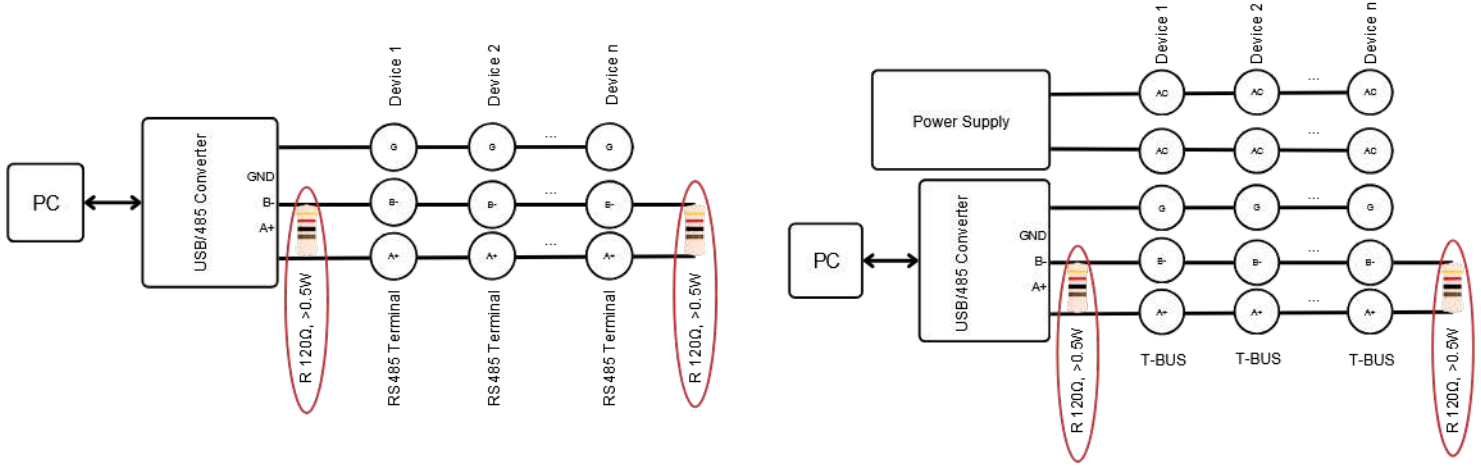
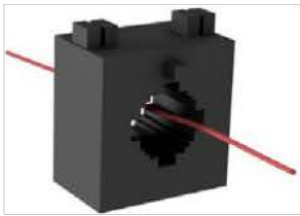

Figure 2: RS485 dynamic bus termination

Example of how to use a current transducer

Depending on the transducer used and the current that has to be measured in the installation, it might be useful to make more than one turn around the transducer's core in order to have the sensed current at the centre of the data acquisition instrument scale. In this case accordingly change the transformer ratio acting on reg. 40102.



Normal installation - 1 turn
(1 conductor's crossing through core)

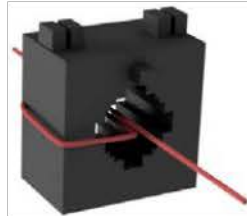

2 turns
(2 conductor's crossing through core)

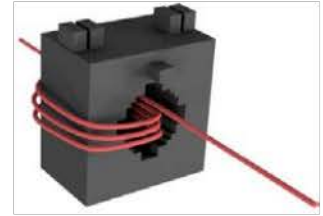

4 turns
(4 conductor's crossing through core)

Figure 3: turns examples



STATUS LEDS

Function	Status	Meaning
Power (green)	ON	Powered device
Fail (yellow)	ON	Presence of one or more module anomalies/errors (configurable via Q-WIZARD or via dedicated registers - see page 21)
RX (red)	Flashing	The system is receiving data from the RS485
TX (red)	Flashing	The system is transmitting data on RS485
Dout (green)	ON	Active digital output

DATA LOGGING – DATA ACQUISITION

The QA-POWER-M is able to provide a series of information regarding the module operation, alarm status, input type, output type, measured data reading, totalization, period and frequency measurement and module output value on a local USB PENDRIVE type memory (USB KEY) connected to the module via the microUSB port. The module is equipped with an RTC Real Time Clock powered by a backup battery, allowing the recording of data with year-month-day-hour-min-sec.

Log file example

Serial	Data (yyyy-mm-dd) & Time	Status	V _{pk}	I _{pk}	V _{rms}	P	CosΦ	Freq.	Energy	Energy+
12345678	2015/03/12-14-23-25	0	270	0	123	85,7	0,91	52	21	0
12345678	2015/03/12-14-23-26	0	270	0	123	88,3	0,92	52,6	21	0
12345678	2015/03/12-14-23-27	0	273	0	123	87,8	0,92	52,4	21	0
12345678	2015/03/12-14-23-28	0	270	0	123	88,1	0,93	52,1	21	0

Serial Number: is the serial number of the module, which allows it to be uniquely identified

Data & Time: log time information (year/month/day-hours-min-sec)

Status ID: STATUS register in 16-bit binary mode

- bit [0] = fail global
- bit [1] = alarm
- bit [2] = over range
- bit [3] = under range
- bit [4] = riservato
- bit [5] = dout status
- bit [6] = fail HW
- bit [7] = fail log
- bit [8] = fail RTC
- bit [9] = fail EEPROM

V_{pk}: voltage peak

I_{pk}: current peak

V_{rms}: voltage root mean square value

I_{rms}: current root mean square value

P: active power

Q: reactive power

S: apparent power

CosΦ: phase shift

Freq.: frequency signal

Energy: measured energy

Energy +: positive measured energy

Energy -: negative energy

Output value: analog output value expressed in uA or in mV



Output type: represents the analogue output configuration

- bit [0] = Voltage/Current
- bit [1-4] = input Vrms, Irms, Active Power, Reactive Power, Apparent Power, Cosφ, Frequency
- bit [5] = fail under-range
- bit [6] = fail over-range
- bit [7] = fail HW
- bit [8] = fail log
- bit [9] = fail RTC
- bit [10] = fail EEPROM
- bit [11] = fail alarm
- bit [12-13] = 0 above threshold /1 below threshold /2 outside thresholds /3 inside thresholds
- bit [14] = Manual mode

PRODUCT FEATURES

The following functions can be configured using the configuration software or the dedicated registers:

Modbus

Address, baud rate, parities and stop bits are adjustable.

Inputs/output

- Selection of the type of input current measurement
- Transformation ratio ([Reg. 40102] in the case of direct connection or CT with current output or reg.[40157, 40159, 40161] in the case of CT with current output)
- Filtering on measurement [Reg. 40131 – 40133]
- Voltage, current and power measurement display limits [Reg. 40135 – 40139]
- Energy (Wh) per pulse [Reg. 40110]
- Analog voltage or current output selection [Reg. 40101]
- Selection of retransmitted analogue output measurement among those available [Reg. 40101] or with manual management via Modbus RTU [Reg. 40101] (with setting of input scaling ranges [Reg. 40104 - 40106] and output [Reg. 40108 - 40109])

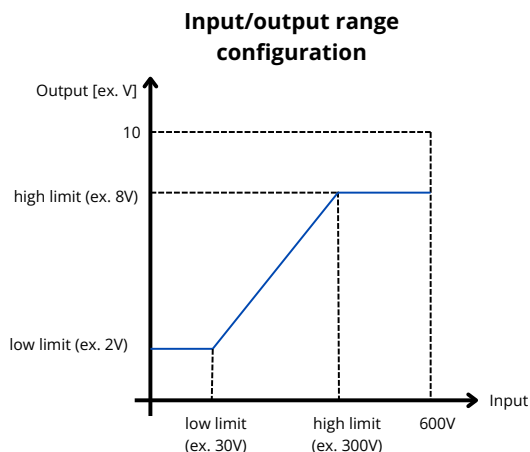

- Enabling digital output and its status at start-up [Reg. 40112]



Analogue output alarm

By configuring the register [40101] it is possible to determine whether an alarm is to be associated with the analogue output (in addition to the value already present on the output itself).

PLEASE NOTE: in the event of an alarm, the output is set to 21mA or 10.5V depending on the analogue output mode setting (current or voltage) selected via the configuration software.

Digital output alarm – pulse counter

If bit[8] of register [40112] is 1, the output is managed as a pulse counter, while if it is 0, it is managed as an alarm. By acting on register [40112], it is possible to define which alarms are to be associated (and, if necessary, the threshold [reg. 40113 - 40115] and hysteresis [reg. 40117] of the value that determines the alarm activation) and whether the alarm is active low/high.

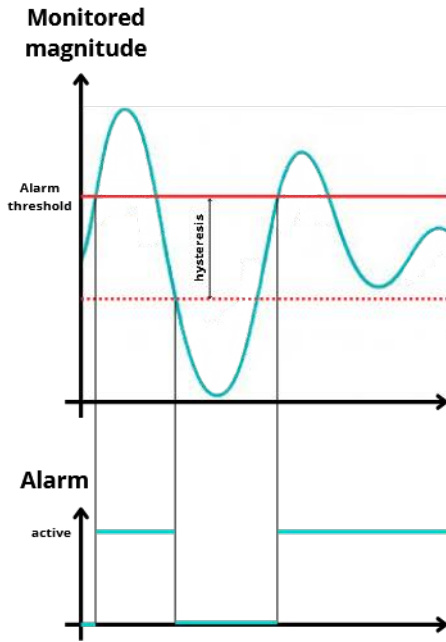

Figure 3: Alarm above threshold

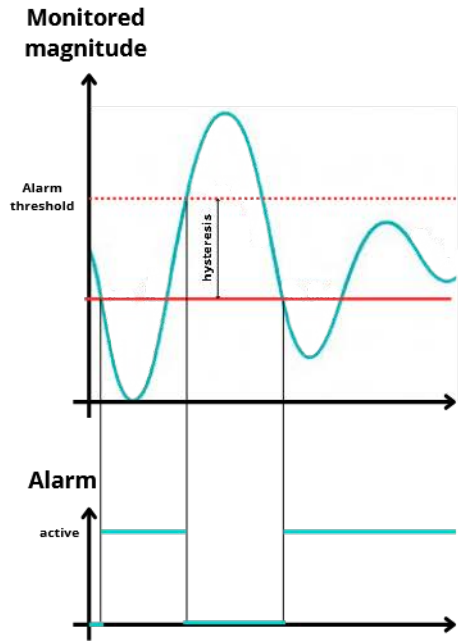

Figure 4: Alarm below threshold

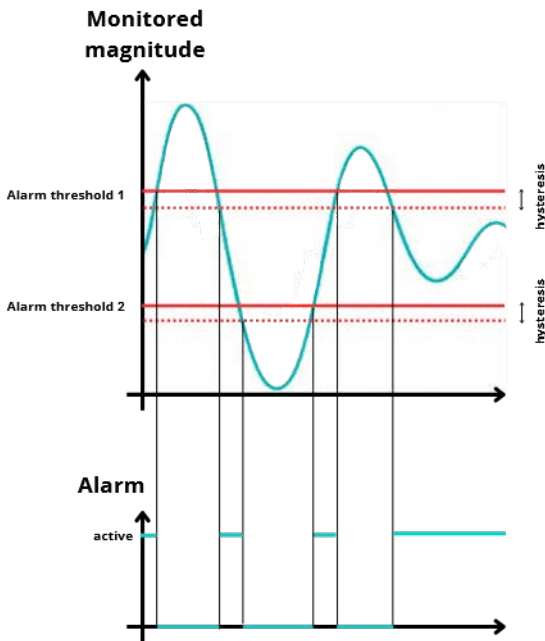

Figure 5: Alarm inside thresholds

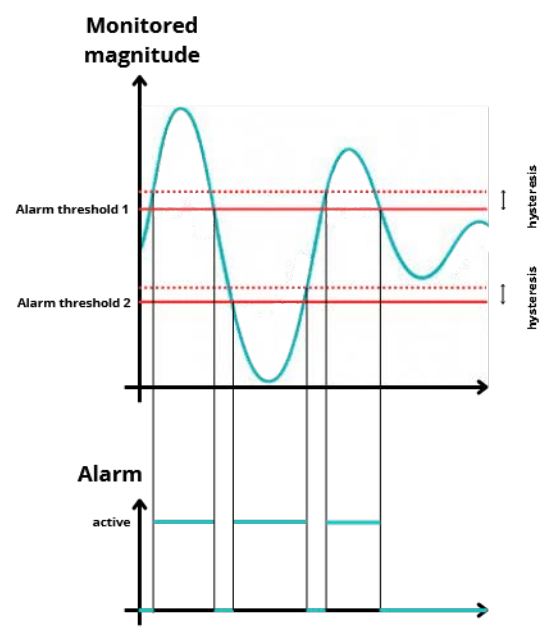
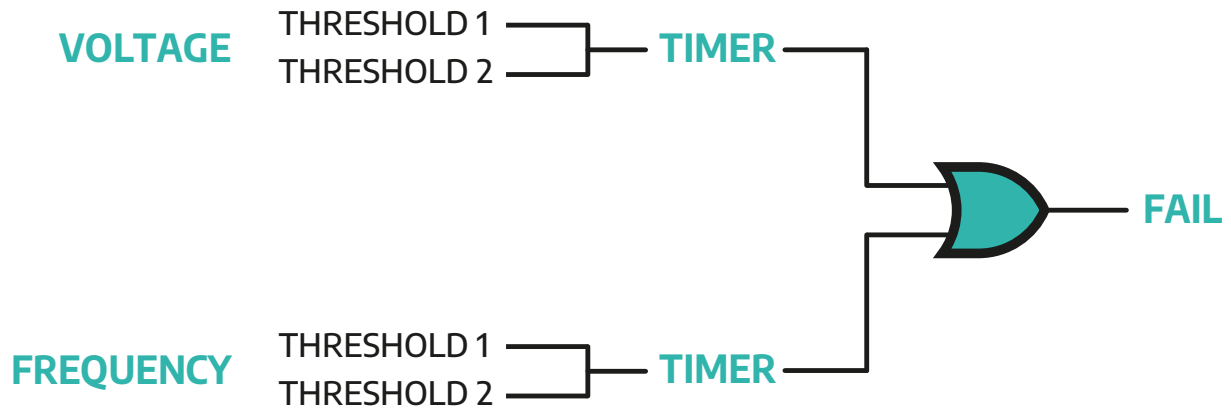

Figure 6: Alarm outside thresholds



Available from firmware version 005: configurable AND/OR digital output alarm according to the following diagram



Two input measurements can be selected via registers [40154] and [40155]. For each input it is possible to set two measurement thresholds which, if exceeded, will trigger the corresponding alarm. These thresholds can be set in registers [40142-40149]. Bits [12-13] and bits [14-15] of register [40112] define the type of threshold (below threshold, above threshold, outside two thresholds, within two thresholds). The alarms are combined according to an AND/OR logic that can be set via register [40141].

An alarm signalling delay can be set via registers [40150-40153].

The alarm status is indicated by bit [11] of register [40112].



DEVICE CONFIGURATION

Dip-switch Modbus RTU address and baud rate setting

The DIP switches on the front of the module can be used to change the Modbus RTU address and baud rate. If all DIP switches are set to zero, the module takes the configuration from the EEPROM, otherwise it takes the configuration set by the DIP switches.

USB OTG	ON							
	1	2	3	4	5	6	7	8
EEPROM	0	0	0	0	0	0		
Add: 1	0	0	0	0	0	1		
Add: 2	0	0	0	0	1	0		
Add: 63	1	1	1	1	1	1		
9600							0	0
19200							0	1
38400							1	0
57600							1	1

Addresses greater than 63 and baud rates other than those selected by the DIP switches can be configured using the **Q-WIZARD configuration tool** or the Modbus RTU functions below by acting on the dedicated registers.

Raising DIP switch 1, visible through the hole in the product casing (see figure below), activates the dynamic termination (120Ω) of the Modbus RTU (to be performed only on the last module in the chain - see Figure 2 under RS485 bus termination).

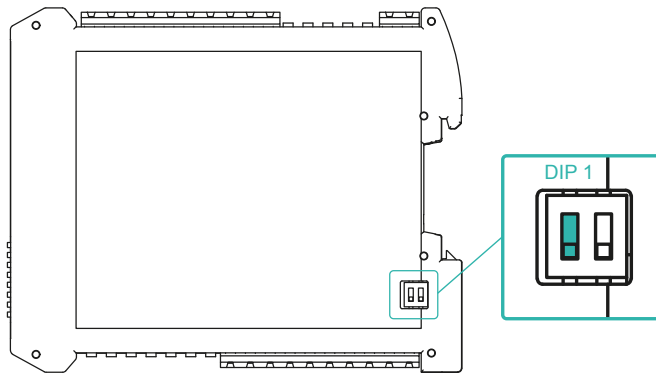

Figure 3: Dip-switch

PLEASE NOTE: To activate any DIP switch changes, it is necessary to switch the unit off and on again.

Functionality configuration

It is possible to connect to the product via an RS485 serial device, such as our Q-USB485, or via the microUSB port.

If the microUSB is used for configuration only, the main power supply from the terminals is not necessary, but it must be present to have all the functions active (real-time monitoring); if configuration is made from the terminals, the power supply must always be present.

The configuration of the module can be done with our **Q-WIZARD** configuration tool or with any third-party Modbus master, by acting on the registers of the card - see page 21.

Q-WIZARD

Using the **Q-WIZARD configuration tool (downloadable from here)**, all device parameters can be configured by following the simple, intuitive steps.

In addition to the configuration of various parameters, inputs and outputs, the **Q-WIZARD** also allows real-time monitoring of device variables.



Third-party Modbus Master

Alternatively, the product can communicate directly with a third-party Modbus RTU Master using the communication settings according to the DIP switch configuration (when using microUSB the DIP switch settings are irrelevant).

The communication protocol supported is Modbus RTU Slave:

- Modbus RTU connections: A+ and B- according to Modbus RTU standards
- Supported Modbus RTU functions: 03 hexadecimal (read multiple registers, max 100), 06 hexadecimal (write single), 10 hexadecimal (write multiple registers)
- Modbus RTU address numbering is by convention '1 BASED' (standard), but the physical register is base 0; the logical address, e.g. 40010, corresponds to the physical address #9, as required by Modbus RTU standards

PLEASE NOTE: All setting changes of calibration and configuration parameters must be followed by the flash save command 0xC1C0 = Flash settings save command in register 42001; changes of device communication parameters in addition must also be followed by the command 0xC1A0 = Reboot command in register 42001.

In this case, all device configurations are performed by accessing the Modbus RTU register map available in the last chapter of this document using the functions:

- Read holding registers (function 03 hexadecimal)
- Write single holding register (function 06 hexadecimal)
- Write multiple registers (function 10 hexadecimal)



Function 03 Hexadecimal (Read Holding Registers)

This function is used to read the contents of a contiguous block of holding registers (words). The request frame specifies the source register address and the number of registers to read. A maximum of 120 registers (words) can be read with a single request, unless otherwise specified. The register data in the response message is packaged as two bytes per register (word), with the binary contents right-justified within each byte. For each register, the first byte contains the most significant bits (MSB) and the second byte contains the least significant bits (LSB).

Request Frame			
Description	Length	Value	Comments
Physical address	1 byte	1 to F7 HEX (1 to 247)	
Function code	1 byte	03 HEX	
Starting address	2 bytes	0000 to FFFF HEX	Bytes order: MSB, LSB
Number of registers (N word)	2 bytes	1 to 10 HEX (1 to 16)	Bytes order: MSB, LSB
CRC	2 bytes		

Response frame (right action)			
Description	Length	Value	Comments
Physical address	1 byte	1 to F7 HEX (1 to 247)	
Function code	1 byte	03 HEX	
Required Number of bytes	1 byte	N word * 2	
Register value	N*2 bytes		Bytes order: MSB, LSB
CRC	2 bytes		

Response frame (wrong action)			
Description	Length	Value	Comments
Physical address	1 byte	1 to F7 HEX (1 to 247)	Possible exception: 01: illegal function 02: illegal data address 03: Illegal data value 04: Slave device failure
Function code	1 byte	83 HEX	
Exception code	1 byte	01, 02, 03, 04 (see note)	
CRC	2 bytes		



Function 06 Hexadecimal (Write Single Holding Register)

This function is used to write a single holding register. The request frame specifies the address of the register (word) to be written and its contents. The correct response is an echo of the request, returned after the contents of the register have been written.

Request frame			
Description	Lenght	Value	Comments
Physical address	1 byte	1 to F7 HEX (1 to 247)	
Function code	1 byte	06 HEX	
Starting address	2 bytes	0000h to FFFF HEX	Bytes order: MSB, LSB
Register value	2 bytes	0000h to FFFF HEX	Bytes order: MSB, LSB
CRC	2 bytes		

Response frame (right action)			
Description	Lenght	Value	Comments
Physical address	1 byte	1 to F7 HEX (1 to 247)	
Function code	1 byte	06 HEX	
Starting address	2 bytes	0000h to FFFF HEX	Bytes order: MSB, LSB
Register value	2 bytes	0000h to FFFF HEX	Bytes order: MSB, LSB
CRC	2 bytes		

Response frame (wrong action)			
Description	Lenght	Value	Comments
Physical address	1 byte	1 to F7 HEX (1 to 247)	Possible exception: 01: illegal function 02: illegal data address 03: Illegal data value 04: Slave device failure
Function code	1 byte	86 HEX	
Exception code	1 byte	01, 02, 03, 04 (see note)	
CRC	2 bytes		



Function 10 Hexadecimal (Write Multiple Registers)

This function is used to write a block of contiguous registers (maximum of 2). The required values to be written are specified in the data field of the request. The data is packed as two bytes per register.

A correct response returns the function code, the starting address and the number of registers written.

Request frame			
Description	Lenght	Value	Comments
Physical address	1 byte	1 to F7 HEX (1 to 247)	
Function code	1 byte	10 HEX	
Starting address	2 bytes	0000 to FFFF HEX	Bytes order: MSB, LSB
Number of registers (N word)	2 bytes	0001 to 0078 HEX	Bytes order: MSB, LSB
Byte counting	1 byte	N word * 2	
Register value	N * 2 bytes	value	Bytes order: MSB, LSB
CRC	2 bytes		

Response frame (right action)			
Description	Lenght	Value	Comments
Physical address	1 byte	1 to F7 HEX (1 to 247)	
Function code	1 byte	10 HEX	
Starting address	2 bytes	0000 to FFFF HEX	Bytes order: MSB, LSB
Number of registers (N word)	2 bytes	0001 to 0078 HEX	Bytes order: MSB, LSB
CRC	2 bytes		

Response frame (wrong action)			
Description	Lenght	Value	Comments
Physical address	1 byte	1 to F7 HEX (1 to 247)	Possible exception: 01: illegal function 02: illegal data address 03: Illegal data value 04: Slave device failure
Function code	1 byte	90 HEX	
Exception code	1 byte	01, 02, 03, 04 (see note)	
CRC	2 bytes		

FIRMWARE UPDATE

Using a standard pendrive to hold the file and a micro-USB OTG cable, the product is ready for firmware updates via the USB port.

To update the firmware, simply remove power from the module, insert the pendrive on the card with the file on it and restore the power supply. At this point the card will automatically download the file and update the firmware without changing the settings during configuration.

The FAIL LED will flash during the update phase.



REGISTER MAP

Default values are in **bold**.

Address Modbus	Description	Register Type	R/W	Default	Range
40001	Machine ID: 3 = QA-POWER-M 33 = QA-POWER-M-LV 67 = QA-POWER-M-5V	UShort [16b]	R		
40002	Firmware FW	UShort [16b]	R		
40005	Status: bit[0] = fail global bit[1] = alarm bit[2] = Fail over-range based on magnitude selected to be reflected on analog output bit[3] = Fail under-range based on magnitude selected to be reflected on analog output bit[4] = reserved bit[5] = Dout status bit[6] = fail HW bit[7] = fail log bit[8] = fail RTC bit[9] = fail EEPROM	UShort [16b]	R/W		
40006	Output Value (mV or uA) (Possibility to write the register only if bit[1] reg.40101 is = 1)	UShort [16b]	R/W		0...20000
40007	Digital output: bit[0] = disabled /enabled	UShort [16b]	R/W	0	
40008	Dip switch status: bit[0] = dip switch position 8 bit[1] = dip switch position 7 ... bit[7] = dip switch position 1	UShort [16b]	R		
40009	Voltage measurement rms (V)	Float [32b-MSW]	R		
40011	Current measurement rms (mA)	Float [32b-MSW]	R		
40013	Active Power Measurement (W)	Float [32b-MSW]	R		
40015	Reactive Power Measurement (VAR)	Float [32b-MSW]	R		
40017	Apparent Power Measurement (VA)	Float [32b-MSW]	R		
40019	Cos φ Measurement	Float [32b-MSW]	R		
40021	Frequency Measurement (Hz)	Float [32b-MSW]	R		
40023	THD Measurement (%)	Float [32b-MSW]	R		
40025	Totale Energy Measurement (Wh)	Float [32b-MSW]	R/W		
40027	Positive Energy Measurement (Wh)	Float [32b-MSW]	R/W		
40029	Negative Energy Measurement (Wh)	Float [32b-MSW]	R/W		
40031	Instantaneous Voltage Peak (V)	Float [32b-MSW]	R/W		
40033	Instantaneous Current Peak (mA)	Float [32b-MSW]	R/W		
40035	Max RMS Voltage (V)	Float [32b-MSW]	R/W		
40037	min RMS Voltage (V)	Float [32b-MSW]	R/W		
40039	Max RMS Current (mA)	Float [32b-MSW]	R/W		
40041	min RMS Current (mA)	Float [32b-MSW]	R/W		
40043	Max RMS Active Power (W)	Float [32b-MSW]	R/W		
40045	min RMS Active Power (W)	Float [32b-MSW]	R/W		
40047	Max Reactive Power (VAR)	Float [32b-MSW]	R/W		
40049	min Reactive Power (VAR)	Float [32b-MSW]	R/W		
40051	Max Apparent Power (VA)	Float [32b-MSW]	R/W		
40053	min Apparent Power (VA)	Float [32b-MSW]	R/W		
40055	Max Cos φ	Float [32b-MSW]	R/W		
40057	min Cos φ	Float [32b-MSW]	R/W		
40059	Max Frequency (Hz)	Float [32b-MSW]	R/W		
40061	min Frequency (Hz)	Float [32b-MSW]	R/W		
40063	Max THD (%)	Float [32b-MSW]	R/W		
40065	min THD (%)	Float [32b-MSW]	R/W		
40067	V average (V)	Float [32b-MSW]	R		
40069	I average (V)	Float [32b-MSW]	R		
40071	Total pulse Dout	UInt [32b-MSW]	R		



Address Modbus	Description	Register Type	R/W	Default	Range
40101	<p>Output Analog mode: bit[0] = Analogue output type 0 → Voltage 1 → Current bit[1-4] = Measurement available on analogue output: 0 = Vrms 1 → Irms 2 → Active Power 3 → Reactive Power 4 → Apparent Power 5 → cos φ 6 → Frequency bit[5] = Fail under-range based on magnitude selected to be reflected on analog output bit[6] = Fail over-range based on magnitude selected to be reflected on analog output bit[7] = Fail HW (internal communication problem between uCs) bit[8] = Fail log bit[9] = Fail RTC bit[10] = Fail EEPROM bit[11] = Alarm on monitored input bit[12-13] = 0 → above threshold 1 → below threshold 2 → outside thresholds 3 → between thresholds bit[14] = Manual mode 0 → OFF 1 → ON</p>	UInt [16b]	R/W		
40102	<p>Current transformer ratio CT ratio = primary current of transducer / secondary current (or voltage) of transducer / (number of turns - if any) [see figure 3] Example: current transducer QI-KCT-10-50/333 (50A primary, secondary 333mV output), no turns --> CT = 150,1501</p>	Float [32b-MSW]	R/W	1	
40104	<p>Low limit of input range Lower input value of current matched to low value of analogue output (reg. 40108)</p>	Float [32b-MSW]	R/W	0	
40106	<p>High limit of input range Higher input value of current matched to high value of analogue output (reg. 40109)</p>	Float [32b-MSW]	R/W	300 (100 for -LV version)	See note ²
40108	<p>Low limit of output range [mV or uA] depending on the type of output set Output value corresponding to low input value set in reg. 40104</p>	UInt [16b]	R/W	0	See note ²
40109	<p>High limit of output range [mV or uA] depending on the type of output set Output value corresponding to high input value set in reg. 40106</p>	UInt [16b]	R/W	10000	See note ²
40110	<p>Delta Energy: Energy increment (Wh) for the generation of a pulse (50ms)</p>	Float [32b-MSW]	R/W	1	1
40112	<p>Digital Output: bit[0] = Power-Up Value bit[1] = Fail under-range based on magnitude selected to be reflected on analog output bit[2] = Fail over-range based on magnitude selected to be reflected on analog output bit[3] = Fail HW (internal communication problem between uCs) bit[4] = Fail log bit[5] = Fail RTC bit[6] = Fail EEPROM bit[7] = Alarm on monitored input bit[8] = Mode: 0 → Alarm mode 1 → Energy pulse mode bit[9] = Don't care bit[10] = Alarm / Fail digital output state: 0 → Low 1 → High</p> <p>From firmware revision 005: bit[11] = status AND/OR alarm: 0 → not active 1 → active bit[12]-bit[13] = threshold type for input measure 1: 0 → under threshold 1 → over threshold 2 → extern two thresholds 3 → between two thresholds bit[14]-bit[15] = threshold type for input measure 2: 0 → under threshold 1 → over threshold 2 → extern two thresholds 3 → between two thresholds</p>	UInt [16b]	R/W		
40113	<p>Alarm threshold for “above” and “below” types or first alarm threshold for “within threshold” and “Outside threshold” types</p>	Float [32b-MSW]	R/W	0	
40115	<p>Second alarm threshold for “within threshold” and “Outside threshold” types Second threshold value must be higher than first threshold.</p>	Float [32b-MSW]	R/W	0	



Address Modbus	Description	Register Type	R/W	Default	Range
40117	Alarm Hysteresis value	Float [32b-MSW]	R/W	0	
40119	Modbus address, parity, stopbits: MSB: modbus address (default address = 1) LSB: bit[0-1] = parity 0 → none 1 → Odd 2 → Even LSB: bit[2] = stop bits 0 → 1 1 → 2	UInt [16b]	R/W	256	
40120	Baudrate Value: 0 = 1200 1 = 2400 2 = 4800 3 = 9600 4 = 19200 5 = 38400 6 = 57600 7 = 115200	UInt [16b]	R/W	3	
40121	Log mode: bit[0] = disabled /enabled	UInt [16b]	R/W	0	
40122	Log sample time (s)	UInt [16b]	R/W	0	
40123	Log name (MAX 15 characters)	UInt [16b]	R/W		
40124	Log name (MAX 15 characters)	UInt [16b]	R/W		
40125	Log name (MAX 15 characters)	UInt [16b]	R/W		
40126	Log name (MAX 15 characters)	UInt [16b]	R/W		
40127	Log name (MAX 15 characters)	UInt [16b]	R/W		
40128	Log name (MAX 15 characters)	UInt [16b]	R/W		
40129	Log name (MAX 15 characters)	UInt [16b]	R/W		
40130	Log name (MAX 15 characters)	UInt [16b]	R/W		
40131	RMS Filter Coefficient 0,997 = 1 second 0,998 = 2 seconds 0,99991 = 3 seconds 0,99995 = 6 seconds 0,99997 = 7 seconds 0,99998 = 10 seconds 0,99999 = 20 seconds	Float [32b-MSW]	R/W	0,99995	
40133	Average measurement filter 0,99 = 1 second 0,993 = 3 secondss 0,999 = 5 seconds	Float [32b-MSW]	R/W	0,99	
40135	Cut off Voltage (V)	Float [32b-MSW]	R/W	0	
40137	Cut off Current (A)	Float [32b-MSW]	R/W	0	
40139	Cut off P (W)	Float [32b-MSW]	R/W	0	
40141	Digital output alarm type: 0 = normal behaviour (rev004 and older) 1 = OR of the alarms ¹ 2 = AND of the alarms ¹	UShort [16b]	R/W	0	
40142	MAX threshold alarm 1 ¹	Float [32b-LSW]	R/W	0	
40144	Min threshold alarm 1 ¹	Float [32b-LSW]	R/W	0	
40146	MAX threshold alarm 2 ¹	Float [32b-LSW]	R/W	0	
40148	Min threshold alarm 2 ¹	Float [32b-LSW]	R/W	0	
40150	Delay alarm 1 (10000 = 1s) ¹	UInt [32b-MSW]	R/W	0	
40152	Delay alarm 2 (10000 = 1s) ¹	UInt [32b-MSW]	R/W	0	
40154	Measure type input 1 ¹ 0 = VRMS 1 = IRMS 2 = ACTIVE POWER 3 = REACTIVE POWER 4 = APPARENT POWER 5 = COS(PHI) 6 = FREQUENCY	UShort [16b]	R/W	0	0..6
40155	Measure type input 2 (see note ¹) 1 = VRMS 1 = IRMS 2 = ACTIVE POWER 3 = REACTIVE POWER 4 = APPARENT POWER 5 = COS(PHI) 6 = FREQUENCY	UShort [16b]	R/W	0	0..6



Address Modbus	Description	Register Type	R/W	Default	Range
40156	Current input selection type: 0 = direct insertion 1 = current transducer with current output 2 = current transducer with voltage output	UShort [16b]	R/W	1	
40157	Current transducer primary input current	Float [32b-MSW]	R/W	2000	
40159	Current transducer secondary output voltage	Float [32b-MSW]	R/W	0,1	
40161	Number of conductor's crossing through the core	UShort [16b]	R/W	1	
40201	Vrms (V) swapped	Float [32b-LSW]	R		
40203	Irms (mA) swapped	Float [32b-LSW]	R		
40205	Active Power (W)	Float [32b-LSW]	R		
40207	Reactive Power (VAR)	Float [32b-LSW]	R		
40209	Apparent Power (VA)	Float [32b-LSW]	R		
40211	Cos ϕ	Float [32b-LSW]	R		
40213	Frequency (Hz)	Float [32b-LSW]	R		
40215	THD (%)	Float [32b-LSW]	R		
40217	Energy (Wh)	Float [32b-LSW]	R/W		
40219	Positive Energy (Wh)	Float [32b-LSW]	R/W		
40221	Negative Energy (Wh)	Float [32b-LSW]	R/W		
40223	Vpk (V)	Float [32b-LSW]	R/W		
40225	Ipk (A)	Float [32b-LSW]	R/W		
40227	Vrms MAX (V)	Float [32b-LSW]	R/W		
40229	Vrms min (V)	Float [32b-LSW]	R/W		
40231	Irms MAX (A)	Float [32b-LSW]	R/W		
40233	Irms min (A)	Float [32b-LSW]	R/W		
40235	Active Power MAX (W)	Float [32b-LSW]	R/W		
40237	Active Power min (W)	Float [32b-LSW]	R/W		
40239	Reactive Power MAX (VAR)	Float [32b-LSW]	R/W		
40241	Reactive Power min (VAR)	Float [32b-LSW]	R/W		
40243	Apparent Power MAX (VA)	Float [32b-LSW]	R/W		
40245	Apparent Power min (VA)	Float [32b-LSW]	R/W		
40247	Cos ϕ MAX	Float [32b-LSW]	R/W		
40249	Cos ϕ min	Float [32b-LSW]	R/W		
40251	Frequency MAX	Float [32b-LSW]	R/W		
40253	Frequency min	Float [32b-LSW]	R/W		
40255	THD MAX (%)	Float [32b-LSW]	R/W		
40257	THD min (%)	Float [32b-LSW]	R/W		
40301	Vrms (V) x 100	Long [32b-MSW]	R		
40303	Irms (A) x 100	Long [32b-MSW]	R		
40305	Active Power (W) x 100	Long [32b-MSW]	R		
40307	Reactive Power (VAR) x 100	Long [32b-MSW]	R		
40309	Apparent Power (VA) x 100	Long [32b-MSW]	R		
40311	Cos ϕ x 100	Long [32b-MSW]	R		
40313	Frequency x 100	Long [32b-MSW]	R		
40315	THD (%) x 100	Long [32b-MSW]	R		
40317	Energy (Wh) x 100	Long [32b-MSW]	R		
40319	Positive Energy (Wh) x 100	Long [32b-MSW]	R/W		
40321	Negative Energy (Wh) x 100	Long [32b-MSW]	R/W		
40323	Vpk (V) x 100	Long [32b-MSW]	R/W		
40325	Ipk (A) x 100	Long [32b-MSW]	R/W		
40327	Vrms MAX (V) x 100	Long [32b-MSW]	R/W		
40329	Vrms min (V) x 100	Long [32b-MSW]	R/W		
40331	Irms MAX (A) x 100	Long [32b-MSW]	R/W		
40333	Irms min (A) x 100	Long [32b-MSW]	R/W		
40335	Active Power MAX (W) x 100	Long [32b-MSW]	R/W		
40337	Active Power min (W) x 100	Long [32b-MSW]	R/W		
40339	Reactive Power MAX (VAR) x 100	Long [32b-MSW]	R/W		
40341	Reactive Power min (VAR) x 100	Long [32b-MSW]	R/W		
40343	Apparent Power MAX (VA) x 100	Long [32b-MSW]	R/W		
40345	Apparent Power min (VA) x 100	Long [32b-MSW]	R/W		
40347	Cos ϕ MAX x 100	Long [32b-MSW]	R/W		
40349	Cos ϕ min x 100	Long [32b-MSW]	R/W		
40351	Frequency MAX x 100	Long [32b-MSW]	R/W		
40353	Frequency min x 100	Long [32b-MSW]	R/W		



Address Modbus	Description	Register Type	R/W	Default	Range
40355	THD MAX (%) x 100	Long [32b-MSW]	R/W		
40357	THD min (%) x 100	Long [32b-MSW]	R/W		
41001	RTC: year (2000-2099)	UInt [16b]	R/W		
41002	RTC: month (1-12)	UInt [16b]	R/W		
41003	RTC: day month (1-31)	UInt [16b]	R/W		
41004	RTC: hour (0-23)	UInt [16b]	R/W		
41005	RTC: minute (0-59)	UInt [16b]	R/W		
41006	RTC: second (0-59)	UInt [16b]	R/W		
42001	Command: 1 = Reboot 2 = Flash settings save 3 = Set factory configuration 4 = Reset Totalizer 5 = Load Totalizer	UInt [16b]	R/W		

Note:

- ¹⁾ Available only from FW rev.05
- ²⁾ Limit depends of the setting of bit[0] of register 40106
 - 0...10000 if bit[0] = 0
 - 0...20000 if bit[0] = 1

LEGEND:

Short [16b] = Signed Short (16 bit)
UShort [16b] = Unsigned Short (16 bit)

Long [32b-MSW] = Signed Long (32 bit - MSW First Register)
Long [32b-LWS] = Signed Long (32 bit - LSW First Register)
ULong [32b-LSW] = Unsigned Long (32 bit - LSW First Register)
ULong [32b] = Unsigned Long (32 bit)

Float [32b-MSW] = Float (32 bit - MSW First Register)
Float [32b-LSW] = Float (32 bit - LSW First Register)

UInt [16b] = Unsigned Integer (16 bit)
UInt [32b-MSW] = Unsigned Integer (32 bit - MSW First Register)
Int [64b-LSW] = Signed Long Long (64 bit - LSW First Register)



D.E.M. SpA

Zona Ind. Villanova 20
32013 Longarone (BL)
ITALIA

www.dem-it.com
www.qeed.it

As standards, specifications, and design change from time to time, please ask for confirmation of the information given in this publication.